

**AIMS INDUSTRIAL
EQUIPMENT MANUFACTURING LLC**

HOISTS

CHAIN HOISTS

We supply a comprehensive range of chain hoists which are sourced from some of the best hoist builders worldwide. This in turn enables us to cover a wide spectrum of technical requirements.

Key variants and options available as below..

DRIVE

- Manual Chain Blocks – Push and Hand Geared
- Electrical Chain Hoists
- Pneumatic Chain Hoist

SPECIFICATIONS

- Multiple suspension option incl. Hook / Shackle suspended hoist, Hoist integrated with monorail trolley – normal headroom, low headroom, extreme low headroom configuration
- Capacities ranging from 125 Kgs to 100 Metric Tons
- Sub-sea application hoists with special surface coating
- Electric Hoist available for both 400V 3ph and 230V 1ph power supply; Hoists also suitable for 50/ 60 Hz supply.
- Pendant Control / Remote Control available for Electric and Pneumatic Hoist

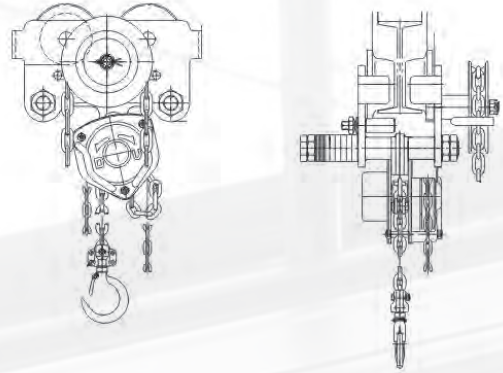

LEVER HOISTS

Available from 250 Kgs to 10 Metric Tons

- Special sub-sea application hoists available with chain locking device
- Several models available for same capacity.



OPTIONS...

Designed to either European FEM/EN/IEC/ISO norms or American CMAA/HMI/NEC standards.

Available for safe working conditions, explosion proof environments – certified to ATEX standard / CMAA / HMI - spark proof versions. Special Corrosion Resistant versions also available.

Comprehensive range of safety features and accessories available for all variants.

All hoists provided with OEM certification as standard. Additional load testing of equipment by third party inspection agencies can be organized on request.

WIRE ROPE HOISTS

Available in 2 major variants, namely Serial Hoist and Barrel Winch type hoist, the wire rope hoists can be supplied based to the following options..

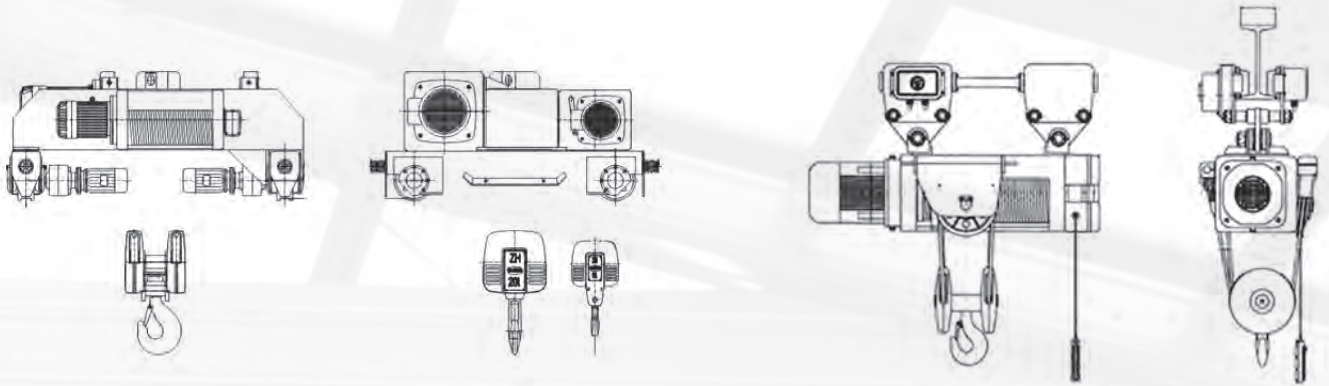

MOUNTING

- Foot Mounted.
- Underhung - suspended from Monorail Trolley.
- Mounted on a bi rail trolley

CAPACITY RANGE

- Serial Hoist: 3.0 – 75.0 Metric Tons.
- Barrel Winch type Hoist: 2.0 – 250 Metric Tons... higher capacities are possible as engineered variants.

EXECUTION

- For safe non hazardous area, both indoor and outdoor
- For corrosive atmosphere, incl. areas with very high salinity or acidic environment
- For explosion proof areas; we can supply hoists designed as per ATEX - IEC - FEM / DIN / EN standards as well as certified as per NEC norms and designed to CMAA / HMI / OSHA standards

LIFTING PATH

- True Vertical Lift using Double Reeving rope drums or 2 parallel hoists working in tandem
- Non True Vertical Lift using Single Reeving hoists

OPTIONS...

Various duty classes depending on the application.

Single / Double / Variable Speeds on all motions

A variety of speed control methods incl. Pole changing / Contactor control, Variable Frequency Drives, PLC controls etc.

Various Safety features like Overload Protection Device, Limit switches, Temperature sensors / Thermistors in motor windings, Over-current protection anti collision, anti sway etc.

Remote controls using Radio Remote / Infrared remote control

SPECIAL: Pneumatic motor driven wire rope hoist also available

CRANES

We manufacture and supply Manual (HOT) & Electric Overhead Travelling (EOT) Cranes for a variety of application and can take up projects on turnkey basis. The electro - mechanical components are sourced from our Technology Partners and the structural part is manufactured locally. The crane is then assembled and tested before being shipped off for installation

Several variants available as below:

HOT CRANES

- Manual Hand Geared Operated Overhead Travelling Crane
- Available in Top running and Under slung variants.
- Capacity Range: 1.0 – 5.0 Metric Tons
- Span: as per client's requirement but generally limited to 12 Mtrs

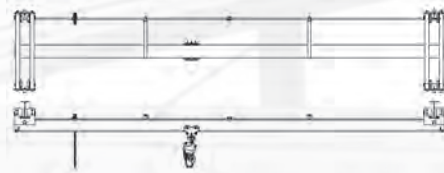
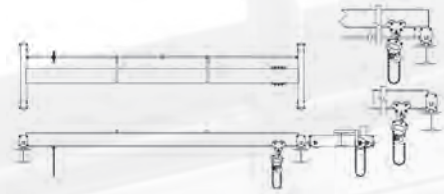

SINGLE GIRDER EOT CRANES

- Capacity Range: 1.0 – 25.0 Metric Tons
- Span: as per client's requirement but generally limited to 25 Mtrs. Longer spans can be supplied as special execution.
- Can be supplied with Electric Chain Hoist or Wire Rope Hoist depending on capacity



DOUBLE GIRDER EOT CRANES

- Capacity Range: 3.0 - 75.0 Metric Tons
- Span: as per client's requirement
- Supplied with Serial Wire Rope Hoist.
- The Girder design and its interface with the end trucks are tailor designed based on the site conditions and overall headroom / column space available.

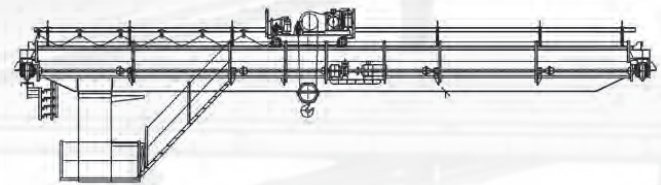

DG EOT CRANES - BARREL WINCH

- Capacity Range: 3.0 - 250.0 Metric Tons, higher capacities available on request
- Span: as per client's requirement
- Supplied with Barrel Winch Wire Rope Hoist, usually tailored as per client's specification
- The crane is a bespoke designed based on client's specification and site conditions.

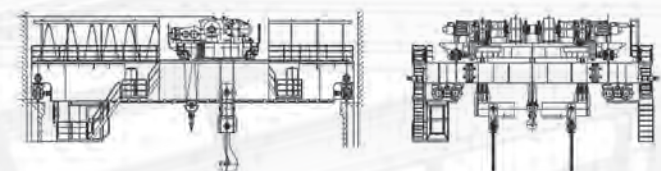

Several option and special features available.

Please contact our Sales Team for a tailored solution to your Overhead Travelling Crane requirements.

GANTRY & SEMI GANTRY CRANES

These are cranes that usually have the bridge girders raised significantly over the end carriages and the crane legs on either side can have the same or different heights. Extremely versatile, these cranes are used in places where putting up a building structure is either not possible or not warranted. Ideal for outdoor duty, these cranes are used inside warehouses and other buildings which are not designed to operate an Overhead Travelling Crane.

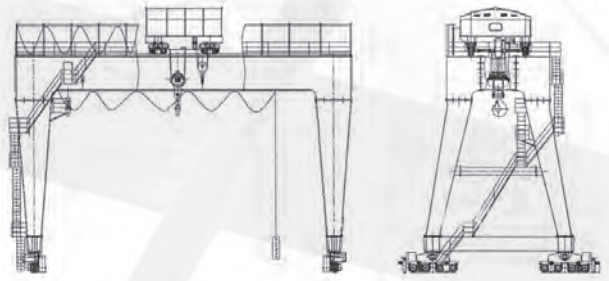

ORIENTATION

- Gantry crane with equal sized legs.
- Gantry crane with unequal sized legs
- Semi Gantry Crane, where one end carriage is directly attached to the girder similar to that in an Overhead Crane

CONSTRUCTION

- Single Girder
- Double Girder.
- Special torsional girder design.

All features available for Overhead Travelling Cranes also applicable for Gantry / Semi Gantry Cranes

JIB CRANES

Jib cranes are lifting equipment where the hoist operates on a single end cantilever arm / jib.

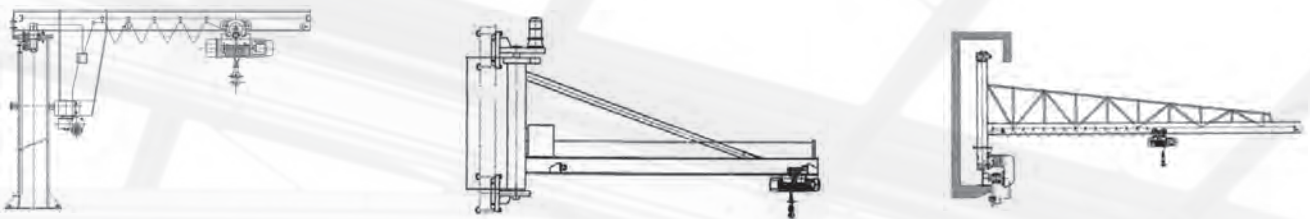

CONSTRUCTION

- Wall mounted Jib Crane, where-in the Jib is fixed to building column or wall
- Pillar Jib Crane: The jib is fixed to a dedicated Pillar and the Jib is capable of rotating around the pillar.
- Travelling Wall Jib Crane: These are specially built Wall type Jib cranes on 3 end trucks / wheels; which allows the crane to laterally travel along the wall of a bay.
- Special Marine / Quay side Application Jib cranes: Custom design cranes for special application

PRIME MOVER

- Manual Jib cranes, where-in the hoist is a manual chain hoist and the swivel is effected by pull / push action or by a hand geared ratchet arrangement.
- Electrical Jib cranes: Where one or more operations is done using an electrical drive
- Pneumatic Jib cranes: These cranes are usually provided with a pneumatic hoist / slew motor.

Jib crane for explosion proof application or for Spark Proof application can be provided, based on both European and American design.

Please refer to our Hoist and Overhead Crane section for other features

Our Sales Team will be happy to assist you with your selection of features for you jib crane.

PROJECTS AND AUXILIARIES

PROJECTS & ENGINEERED PRODUCTS

AIMS Lifting, in collaboration with several reputed Engineering OEM's can design and execute projects in various heavy engineering verticals. A brief list of areas we deal with includes:

- Steel Plant Equipment and Projects
- Luffing Cranes, Container handling cranes, Bulk Material handling cranes for Ports, Railways and storage yards
- Cement / Gypsum plants Equipment and Projects
- Other metallurgical plants and equipment for Aluminum, Copper, Zinc and other metals.
- Ore handling and processing equipment
- Any other bespoke engineered project

Apart from these, we can detail engineer, fabricate, machine, assemble, test and deliver any electro - mechanical equipment as per client's engineering drawings and specifications. Please let us know of your requirement and we will be happy to provide you with a solution.

OTHER PRODUCTS AND AUXILIARIES

CRANE / HOIST CONTROL SYSTEMS

- Flat / Round cable type festoon system on "C" Track with Push Button Pendant Station for Electric Hoists and Cranes
- Round flexible Hose type festoon system on "C" Track with Push Button Station or Lever Control Station for Pneumatic Hoists and Cranes
- Radio Remote for Electric / Pneumatic Hoists
- Infrared Remote for Electric / Pneumatic Hoists
- A/C Cabin with Joystick / Push Button controls to be used with Overhead Travelling, Gantry and large Jib Cranes

POWERLINE SYSTEMS

- PVC enclosed type powerline systems
- Open rail type conductor systems for higher kW applications
- Flat cable / round cable with trolleys on C Track - festoon power systems
- Energy chains with armored cables for heavy duty application
- Spring and Powered Cable Reels for cranes

RAILS AND CLIPS

- Bulb headed rails with weldable / bolttable clips & rail welding kits
- Rectangular / Square bar type rails

BELOW THE HOOK ATTACHMENT

- Clamps, Grabs, Magnets and other material handling attachments
- Spreader Beams, Coil Tongs, Slab Tongs, Crane forks, C Hooks, specialized handling attachments
- Container Lifting Lugs

OTHER MATERIAL HANDLING PRODUCTS

- Winches: Manual, Electrical, Pneumatic for various application
- Pallet Trucks, Pedestrian Stackers, Lifting Platforms & Scissor Lifts
- Load Dollies, Lifting Davits & portable cranes



AIMS SERVICE

An independent group dedicated to repair, refurbishment, retrofitting, upgradation and servicing of all makes of Overhead Cranes, Gantry Cranes, Jib Cranes, Monorail hoists and their related systems and accessories. The group is supported by our own maintenance workshops in Dubai, UAE and Dammam, KSA.

WE SPECIALIZE IN..

- Installation and commissioning of all types of cranes and hoists
- Troubleshooting and Breakdown Maintenance of cranes and hoists incl. detection of faults, onsite repairs and re-commissioning as necessary.
- Repair of damaged cranes and hoist both in-situ or off site as the need maybe.
- Preventive Maintenance Contracts backed by our in-house database management system, to take care of an individual equipment or complete material handling systems at a particular site. We offer a comprehensive "Equipment Health check" for any material handling equipment, pursuant to which, a unique Preventive Maintenance Schedule is drawn up for each equipment.
- Upgradation, retrofitting and servicing of old cranes and hoists, incl. detailed inspection of girder structure, repair and strengthening as necessary, ensuring integrity of repaired structural, repair / replacement of mechanical and electrical parts, complete degreasing / surface preparation / application of new paint or surface protection as necessary.
- Re-assembly of repaired crane / hoist. No load and Full load testing of all drives, control systems and instrumentation to ensure perfect functionality of the assembled equipment.
- Static Load Testing of Hoists in our own workshop and complete static cum dynamic testing of cranes and hoist at site leading to successful commissioning.
- Supply of Spare Parts as necessary.

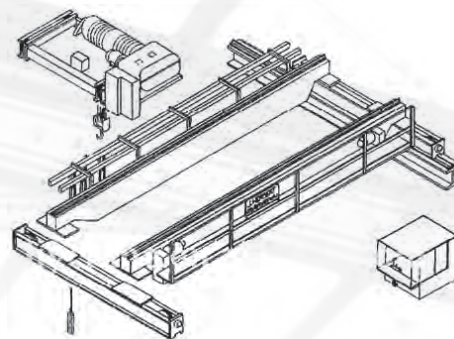

ABOUT US

AIMS Industrial Equipment Manufacturing LLC, is an Industrial Equipment manufacturing, trading and servicing company, located in Dubai, UAE and we are a part of the **Global Union Alliance Co. Ltd. (GUAC)**, Saudi Arabia

GUAC is headquartered in Riyadh, Saudi Arabia and has multiple business interests including International Freight and Logistics, Material Testing Labs, Equipment Manufacturing, Industrial Trading and Allied Services. GUAC has offices in Dubai, Dammam, Riyadh, Jeddah, Yanbu, Muscat and has affiliated partners in Bahrain and Doha.

شركة اتحاد وتحالف العالمية
Global Union Alliance Company Ltd



AIMS INDUSTRIAL EQUIPMENT MANUFACTURING LLC

OFFICE

P.O.Box. 214270, Office# 501, CEO Building
Dubai Investment Park 1, Dubai, United Arab Emirates

T: +971 4 883 3939 **F:** +971 5 883 2298

E: sales@aimslifting.com **W:** www.aimslifting.com

WORKSHOP

Warehouse # 12, Dubai Investment Park 2,
GPS Coordinates: LAT 24.987933 N \ LON 55.208326
Dubai, United Arab Emirates

T: +971 4 881 4442 **F:** +971 4 881 4443

